



SPHEROS

Premium bus heater

▶ Thermo S 160/230/300/350/400

Innovative heating technology,
because the future should be clean



Spheros Thermo S heaters are the logical answer to future demands in bus travel. Environmental compatibility, low LC costs and enhanced performance were the focal points of development. The innovative heating system points the way and demonstrates that also in the future we will maintain our position as market leader in bus climate control.

► Thermo S 160 / 230 / 300 / 350 / 400

Cross-section Thermo S

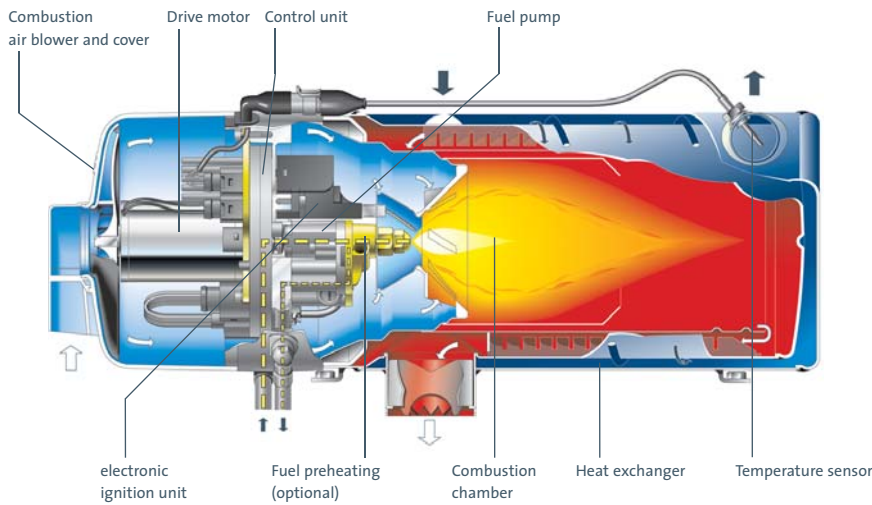

Highlights

- 5 performance levels from 16 to 40 kW
- Low LCC due to reduced fuel consumption, low maintenance and longer durability
- Significantly below future emission limits
- Noise-optimised
- Suitable for operation with alternative fuels
- Interface compatibility to Spheros Thermo heaters – compatibility with OE-diagnosis possible

Exhaust emission values of Spheros Thermo S heaters compared to requirements for commercial vehicle combustion engines

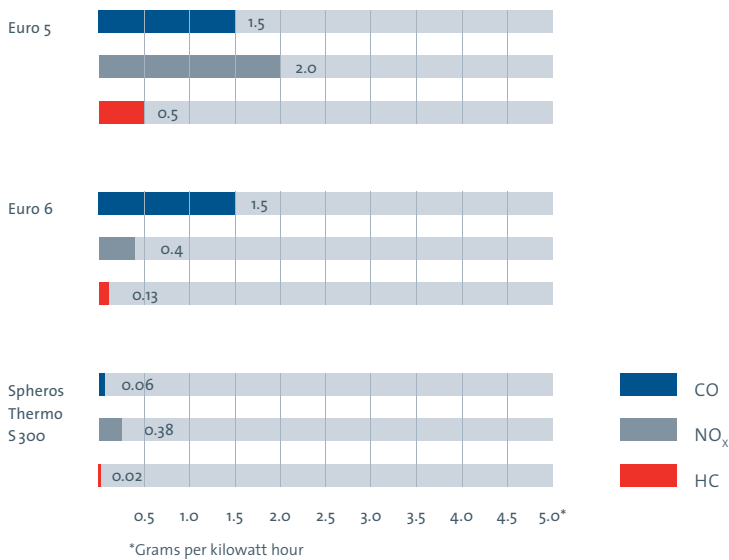

Spheros Thermo test diagnosis for fast data retrieval in case service is needed.

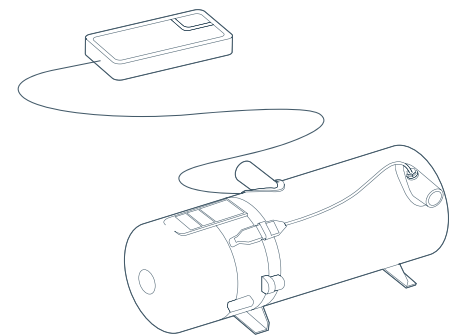

Technical data	Thermo S 160	Thermo S 230	Thermo S 300	Thermo S 350	Thermo S 400
Heat output (kW)	16	23	30	35	40
Electr. power consumption (W)	50	65	90	120	170
Fuel consumption (l/h)	1.9	3.0	3.6	4.3	4.9
Rated voltage (V)	24	24	24	24	24
Dimensions L x W x H (mm)	600 x 247 x 220				
Weight (kg)	18				